

The Analog Linearization of Pt100 Working Characteristic

Radojle Radetić¹, Marijana Pavlov-Kagadejev², Nikola Milivojević³

Abstract: The most exact temperature measurement can be made by using platinum sensors. Temperatures from -254.3 °C up to $+850$ °C can be measured with Pt100 sensor. The relationship between resistance and temperature is relatively linear, but for measurements of very high precision, Pt100 working curve should be a little bit improved. The paper describes an efficient way of measurement characteristic linearization by using the analogue electric circuits. The obtained results proved the initial considerations and the Pt100 becomes rather transducer than pure sensor.

Keywords: Temperature measurement, Pt100 temperature sensor, Measurement working characteristic, Transfer function linearization.

1 Introduction

A platinum resistance temperature detector (RTD) Pt100 is a device with a typical resistance of 100Ω at 0 °C (it is called Pt100) and belongs to class of passive (parametric) sensors [1]. It changes its own resistance value as the temperature changes following a positive slope (resistance is increasing with temperature increasing) [2]. To measure those resistance variations, the external supply is needed. In general, the transducer working characteristic (transfer function) is the relation between measured physical value and appropriate electrical output [3] and can be expressed by relation (1) illustrated in Fig. 1.

$$y = f(x), \quad (1)$$

where x is transducer input value, y is transducer output and $f(x)$ is conversion, or transfer function. Linearity is an important transducer characteristic. It is defined as closeness of transducer's calibration curve to specified straight line [2]. The difference between theoretical (linear) and real measuring characteristic is expressed by deviation, called nonlinearity and can be seen in Fig. 1.

¹Serbian Transmission System, Nade Dimić 40, 19210 Bor, Serbia; E-mail: radojle.radetic@ems.rs

²Institute for Mining and Metallurgy; Zeleni bulevar 35, 19210 Bor, Serbia;

E-mail: marijana.pavlov@irmbor.co.rs

³University of Colorado at Boulder, 435 UCB, Boulder CO 80309-0435, USA;

E-mail: nikola.milivojevic@colorado.edu

Theoretically, it is an inverse function of (1), and can be expressed by simple formula

$$x = f^{-1}(y). \quad (2)$$

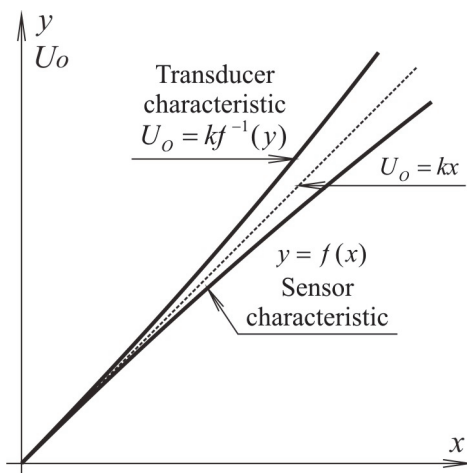

Fig. 1 – The transducer working characteristics.

Fig. 1. consists of sensor function, transducer characteristic and theoretical curve. It can be concluded that sensor output signal (voltage, or current) should be proportional to measured (physical quantity) value. It means that sensor output voltage U_o can be shown as:

$$U_o = kx = kf^{-1}(y), \quad (3)$$

where k is proportionality coefficient ($V/^\circ C$, for example). The above expression shows that transducer function has to be identical (in its form) to inverse sensor characteristic [4].

It is a general approach, but, in practice, the characteristic linearization is more difficult. Of course, the effects are much better if nonlinearity is less evident.

As RTD resistance is proportional to temperature, applying specific current value produces output voltage increasing with temperature. When we are familiar with exact relationship between resistance and temperature, it allows us to calculate the measured temperature value. In practice the Pt100 relationship (measuring characteristic) appears relatively linear, but the working curve is not the exact straight line, Fig. 2. It could be described by the following generic equation, which presents nonlinear relationship between temperature and resistance:

$$R(t) = R_0 (1 + at + bt^2 + c(t-100)t^3), \quad (4)$$

where: $a = 3.9083 \cdot 10^{-3} \Omega/^\circ\text{C}$, $b = -5.775 \cdot 10^{-7} \Omega/^\circ\text{C}^2$, $c = -4.183 \cdot 10^{-12} \Omega/^\circ\text{C}^4$ below 0°C , and zero above 0°C .

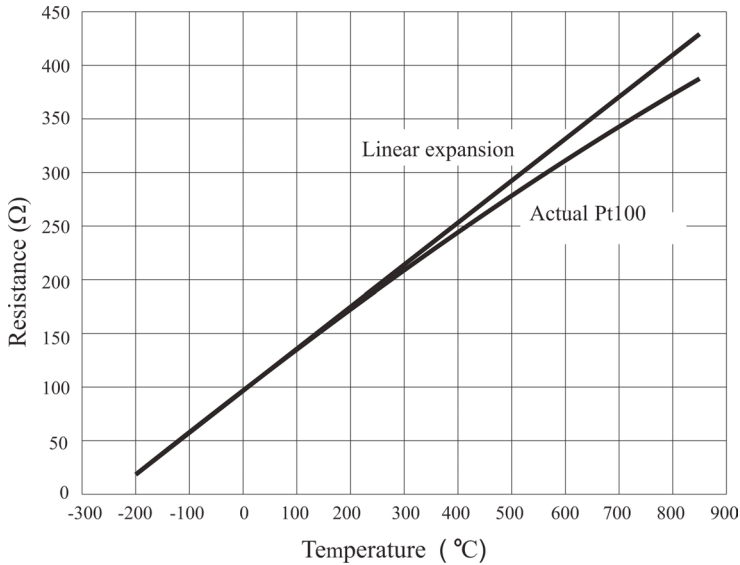

Fig. 2 – Pt100 transfer function.

RTDs have a significant second-order nonlinearity of approximately 0.38% per 1°C of measurement temperature range (see Fig. 2). This nonlinearity is often corrected digitally [5], but there are many applications for purely analog processing and linearization of the RTD transfer function.

There are numerous methods for transducers characteristics linearization, but the paper describes two, practically applied at Pt100 temperature sensor. One of them is the positive feedback application and the other one is the usage of diodes and measuring characteristic breaking (segmentation).

2 The Positive Feedback Linearization Method (briefly)

The method is applicable for the passive sensors with electrical resistance changing output only. Using that way of linearization, very high accuracy and stability can be reached. Certainly, the method gives better results if the sensor characteristic is more linear. But its application is limited for the parametric sensors with working curve below the theoretical straight line [6]. Typical circuit configuration with error compensation [7] and Pt100 working characteristic linearization is shown in Fig. 3.

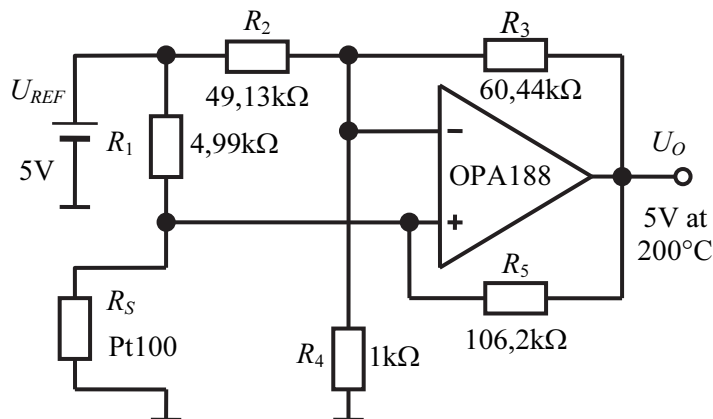

Fig. 3 – Typical circuit for error compensation.

The resistance R_1 provides the primary excitation current from U_{REF} through Pt100, a stable voltage reference. The correction of that current is done by operational amplifier output current through the resistor R_5 . For the temperature interval 0 to 200°C the values of R_2 , R_3 , and R_4 are chosen to provide the required amplifier gain and offset so, to produce the desired output-voltage range.

3 Proposed (improved) Way of Linearization

To reach the better characteristic linearization, the improved electrical schema is designed, Fig. 4. The temperature sensor Pt100 (R_S) is connected in the positive feedback branch. The R_S resistance variation due to temperature changing causes changing of the first amplifier output. That voltage is further amplifying by the second amplifier giving the output signal U_O .

By resistance R_2 the output voltage U_O is set to zero for temperature 0°C. That output voltage would be directly proportional to Pt100 resistance without positive feedback via R_5 . The feedback is positive and the output voltage increase causes current increasing through Pt100 sensor.

The current changing is very linear (see Fig. 5) and its increasing makes the greater sensor voltage drop. On that way the sensor nonlinearity is compensated, because the measuring characteristic is below linear working curve, ($y = f(x)$ on Fig. 1).

For the circuits in Fig. 4. the output voltage can be calculated as

$$U_O = \frac{R_S R_4}{R_2} \left(\frac{U_{REF}}{R_1} + \frac{U_O}{R_5} \right) - U_{REF} \frac{R_4}{R_3}, \quad (5)$$

or explicitly

$$U_O = U_{REF} \frac{R_4 R_5 (R_S R_3 - R_1 R_2)}{R_1 R_3 (R_2 R_5 - R_S R_4)} \quad (6)$$

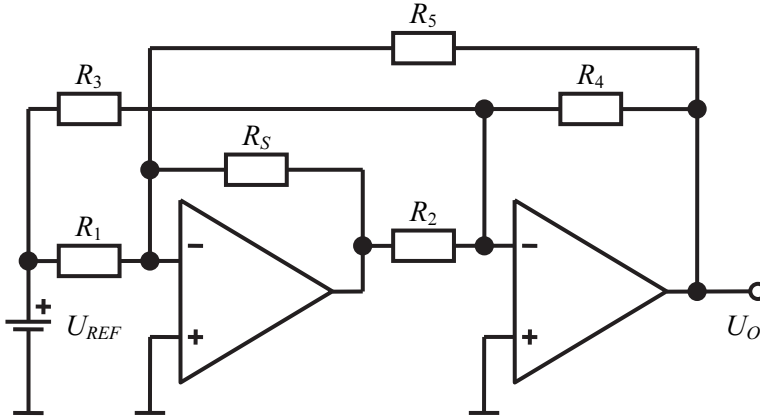

Fig. 4 – The modified linearization circuit.

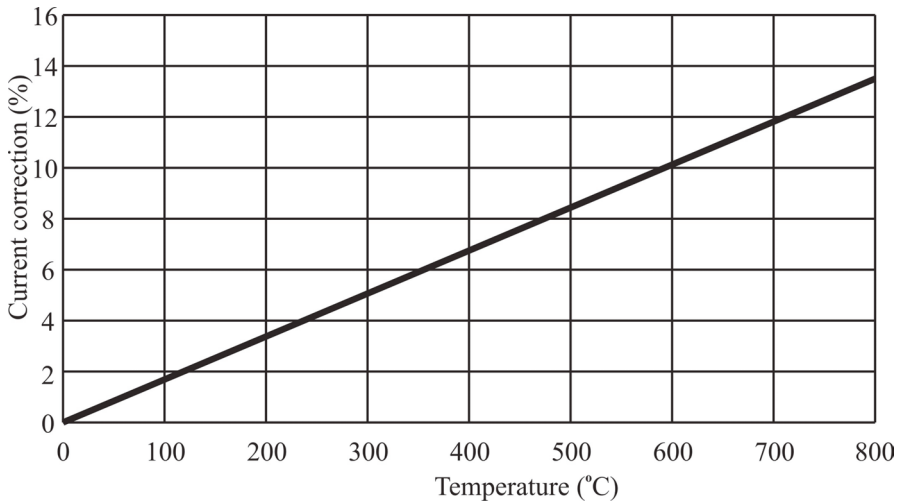

Fig. 5 – The current correction diagram.

To define the values of the above resistors, the referent voltage will be set to $U_{REF} = 10 \text{ V}$. The current intensity through Pt100 would be low enough not to cause the self-heating error, but also, high enough to provide the desired measuring accuracy. It means that the acceptable value of current intensity

should be about 1 mA. Considering that the assumed referent voltage is 10 V, the resistance has to be $R_1 = 10 \text{ k}\Omega$. If the transmissions constant is the decade value, for example $k = 10 \text{ mV}/^\circ\text{C}$, for the maximal measuring temperature (about 800°C) the output voltage will reach 8 V. Calculating the values of the other resistors of electrical schema (see Fig. 4) will be carried out according to chosen points the measuring characteristic has to pass through. The first one is the point $T_1 = 0^\circ\text{C}$, $R_{S,1} = 100 \Omega$ and output voltage $U_{O,1} = 0 \text{ V}$. Importing those values in (6), the following is obtained

$$R_3 = \frac{R_1 R_2}{R_{S1}} \quad (7)$$

and output voltage value will be

$$U_o = \frac{U_{REF}}{R_1} \frac{R_4}{R_2} \frac{(R_S - R_{S1})}{\left(1 - \frac{R_S R_4}{R_5 R_2}\right)}. \quad (8)$$

The values of the other resistors will be calculated according to the requirements the transducers working curve has to pass through two temperature points T_2 and T_3 , where the Pt100 resistances are $R_{S,2}$ and $R_{S,3}$, providing the transducers output voltages $U_{O,2}$ and $U_{O,3}$ respectively. Using those conditions next two equations are originated

$$\frac{R_4}{R_2} = \frac{U_{O,2} U_{O,3}}{U_{REF}} \frac{R_1 (R_{S3} - R_{S2})}{U_{O,3} R_{S3} (R_{S2} - R_{S1}) - U_{O,2} R_{S2} (R_{S3} - R_{S1})}, \quad (9)$$

$$R_5 = R_1 \frac{U_{O,3}}{U_{REF}} \frac{(R_{S3} - R_{S2})}{\left[\frac{U_{O,3}}{U_{O,2}} (R_{S2} - R_{S1}) - (R_{S3} - R_{S1}) \right]}. \quad (10)$$

It is much better to use numerical values obtained in previous equations, than to manipulate with those cumbersome (robust) expressions (9) and (10). The whole measuring range is separated into four temperature areas. The calculated values of the resistors and the appropriate output voltage signals as the transducer characteristics (output voltage U_o) for three desired temperature points are shown in the **Table 1**. The table contains four columns, for four linearization zones.

It is easy to verify the performed approximation accuracy. Importing the values of R_S from the standard lookup tables EN 60751 (ITS 90) gives the opportunity for calculating U_o values and the obtained results match every temperature according to constant $k = 10 \text{ mV}/^\circ\text{C}$. **Table 2** shows the relative errors for each of four linearization. The referent values of R_S in second column are taken from standard EN 60751 (ITS 90) [7]. As it can be seen, the first

linearization gives pretty acceptable relative error in the range -100 °C to 400 °C, but for the very high temperatures it becomes greater than 1%. The second linearization has the widest temperature interval with error below 0.2%. And, quite reasonably, the fourth linearization is more convenient for higher temperature measurement (above 300 °C). For the low temperatures the relative error is a little bit greater. Fig. 6. shows the relations of relative errors and measuring temperatures for four cases given in **Table 2**. This analyzes and consideration can be taken as working characteristic fragmentation [8].

Table 1
The calculated resistance values for circuit in Fig. 4.

$T_1=0^{\circ}\text{C}$ $T_2=100^{\circ}\text{C}$ $T_3=200^{\circ}\text{C}$	$T_1=0^{\circ}\text{C}$ $T_2=200^{\circ}\text{C}$ $T_3=400^{\circ}\text{C}$	$T_1=0^{\circ}\text{C}$ $T_2=300^{\circ}\text{C}$ $T_3=600^{\circ}\text{C}$	$T_1=0^{\circ}\text{C}$ $T_2=400^{\circ}\text{C}$ $T_3=800^{\circ}\text{C}$
$U_{REF}=10\text{ V}$	$U_{REF}=10\text{ V}$	$U_{REF}=10\text{ V}$	$U_{REF}=10\text{ V}$
$R_1=10\text{ k}\Omega$	$R_1=10\text{ k}\Omega$	$R_1=10\text{ k}\Omega$	$R_1=10\text{ k}\Omega$
$R_2=10\text{ k}\Omega$	$R_2=10\text{ k}\Omega$	$R_2=10\text{ k}\Omega$	$R_2=10\text{ k}\Omega$
$R_3=1\text{ M}\Omega$	$R_3=1\text{ M}\Omega$	$R_3=1\text{ M}\Omega$	$R_3=1\text{ M}\Omega$
$R_4=246.01\text{ k}\Omega$	$R_4=245.22\text{ k}\Omega$	$R_4=244.11\text{ k}\Omega$	$R_4=242.65\text{ k}\Omega$
$R_5=646.19\text{ k}\Omega$	$R_5=616.77\text{ k}\Omega$	$R_5=586.70\text{ k}\Omega$	$R_5=556.77\text{ k}\Omega$

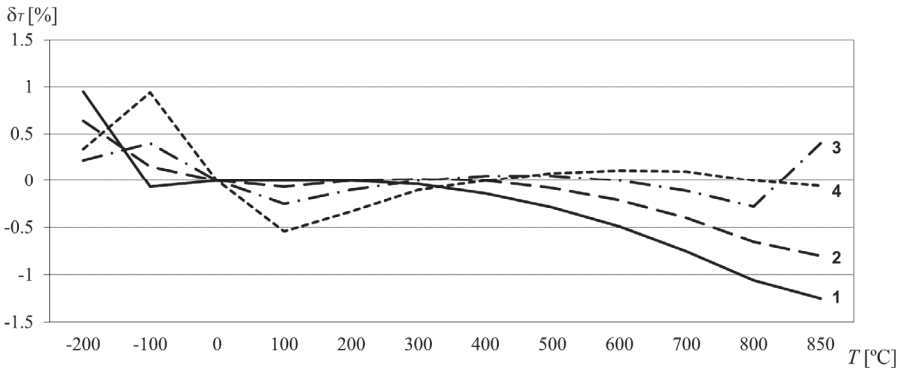

Fig. 6 – The relative error diagram for all linearizations in **Table 2**, respectively.

Because of some parameters nominal values deviation, it is necessary to allow the additional calibration. The resistors R_3 , R_4 and R_5 are critical. That is why they need to be chosen with some percentage lower resistances, and then

add the serial trimmer potentiometers ΔR_3 , ΔR_4 and ΔR_5 (see Fig. 7). The precise resistance decade (or appropriate fixed resistors) should be connected at the converter input.

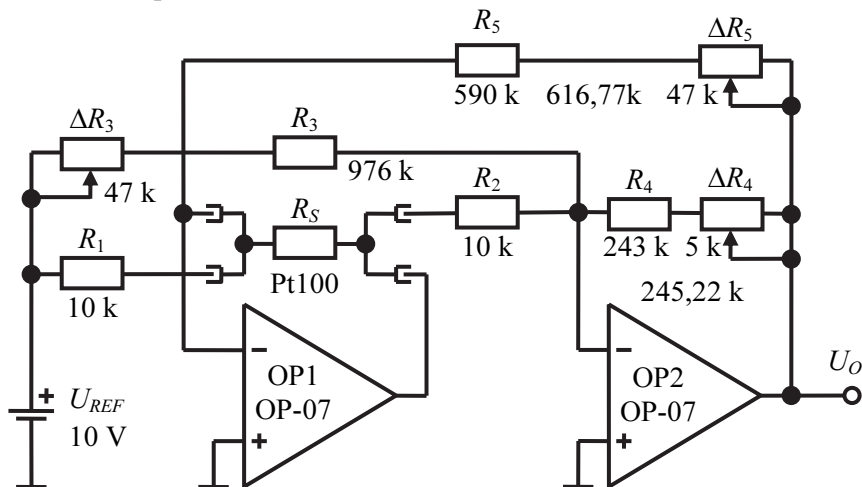

Fig. 7 – Pt100 compensation circuit with additional potentiometers.

The calibration process for the second linearization (see **Table 2**) could be done in the following way:

- the input resistance has to be set to 100.000 Ω and using the potentiometer ΔR_3 , the output voltage must be adjusted to 0 V,
- with input resistance of 175.856 Ω by trimmer ΔR_4 the output voltage has to be read,
- using the input resistance of 247.092 Ω and potentiometer ΔR_5 the output must be adjusted to 4 V.

Performing the last step disturbs the output signal and it will not be exactly 2 V (for 200 °C). That is why the last two steps have to be repeated a couple of times to reach satisfactory accuracy. The same calibration procedure is to be performed for each linearization shown in **Table 2**.

The Fig. 7 shows the four-wire connection with resistance values calculated for second linearization approach (column 2 in **Table 1**). Pt100 RTD can be connected to the measuring application using two wires, three wires, or four wires. An additional third wire to the RTD allows compensation for the wire resistance.

The only restriction is that the main connecting wires have the same characteristics. A four-wire approach enables Kelvin sensing, which eliminates

the effect of voltage drops in the two connecting wires. In practice, sensor is usually distant from the transmitter and some noise and disturbance in the cables occur. To prevent those unwanted appearance the appropriate capacitors has to be connected in the feedback of both amplifiers. It is necessary to use one additional resistor of about 10 kΩ at the input of first amplifier for its protection (R_1 in Fig. 7).

Table 2
The linearization relative errors δ_T .

		$T_1=0^\circ\text{C}$ $T_2=100^\circ\text{C}$ $T_3=200^\circ\text{C}$		$T_1=0^\circ\text{C}$ $T_2=200^\circ\text{C}$ $T_3=400^\circ\text{C}$		$T_1=0^\circ\text{C}$ $T_2=300^\circ\text{C}$ $T_3=600^\circ\text{C}$		$T_1=0^\circ\text{C}$ $T_2=400^\circ\text{C}$ $T_3=800^\circ\text{C}$	
		$U_o = \frac{24.601 \cdot 10^{-3} (R_s - 100)}{1 - 0.38071 \cdot 10^{-4} R_s}$ [V]		$U_o = \frac{24.522 \cdot 10^{-3} (R_s - 100)}{1 - 0.39759 \cdot 10^{-4} R_s}$ [V]		$U_o = \frac{24.411 \cdot 10^{-3} (R_s - 100)}{1 - 0.41607 \cdot 10^{-4} R_s}$ [V]		$U_o = \frac{24.265 \cdot 10^{-3} (R_s - 100)}{1 - 0.43582 \cdot 10^{-4} R_s}$ [V]	
T [°C]	R_S [Ω]	U_o [V]	δ_T [%]	U_o [V]	δ_T [%]	U_o [V]	δ_T [%]	U_o [V]	δ_T [%]
-200	18.520	-2.0187	0.95	-2.0129	0.64	-20.044	0.22	-19.932	0.34
-100	60.256	-1.0007	-0.07	-0.9985	0.15	-0.9951	0.40	-0.9905	0.94
0	100.000	0.0000	0.00	0.0000	0.00	0.0000	0.00	0.0000	0.00
100	138.506	1.0000	0.00	0.9993	-0.07	0.9975	-0.25	0.9944	-0.54
200	175.856	2.0000	0.00	2.0000	0.00	19.979	-0.10	19.934	-0.33
300	212.052	2.9988	-0.04	3.0007	0.02	30.000	0.00	29.958	-0.10
400	247.092	3.9944	-0.14	4.0000	0.00	40.021	0.05	40.000	0.00
500	280.978	4.9855	-0.29	4.9961	-0.08	50.027	0.05	50.042	0.08
600	313.708	5.9705	-0.49	5.9873	-0.21	60.000	0.00	60.069	0.11
700	345.284	6.9475	-0.75	6.9719	-0.40	69.922	-0.11	70.061	0.10
800	375.704	7.9146	-1.06	7.9480	-0.65	79.772	-0.28	80.000	0.00
850	390.481	8.3939	-1.25	8.4323	-0.80	84.664	0.40	84.941	-0.06

4 Using Diodes for Linearization Improvement

The additional linearization improvement can be done by using diodes. This method allows very significant error decreasing in the whole Pt100 measuring range. The resistance numerical values are calculated using simulation procedure by varying the parameters in a computer program. The Electronic Workbench – EWB (Version 5.0c – Educational Network) is in question. The schema in Fig. 8. is originated using those results.

The basic linearization was performed by positive feed back in three temperature points of 0°C, 100°C and 200°C. The additional correction is done by resistors R_8 to R_{12} and the diodes D_1 , D_2 and D_3 . The resistors R_8 , R_9 , R_{10} and R_{11} form three-level voltage divider. At higher temperatures (over 300°C) R_6 via

D_1 , and R_7 via D_2 over 600°C raise the working curve as well. In case of low temperature (below -100°C) the correction is done by R_{12} and D_3 . At electronic circuit in Fig. 8. the simulation method shows the error below 0.01°C in the whole range (-200°C to $+850^\circ\text{C}$).

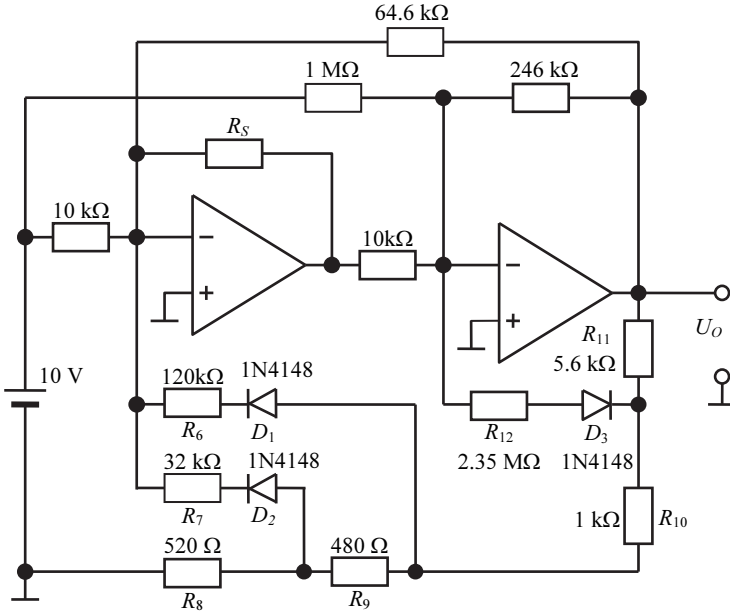

Fig. 8 – The improved temperature measurement circuit.

The EWB program calculated values for the above arrangements are given in **Table 3**. The second large column contains the values for standard linearization circuit shown in Fig. 3. The data in third column belong to modified linearization circuit in Fig. 4, and the right column presents the data obtained by workbench program applied on the diode improvement circuit shown in Fig. 8, **Table 3**.

Obviously, the most convincing results in the whole measuring range are achieved by added diode linearization method. The Fig. 9 shows it on the most persuasive way.

The current passing through sensor will cause some heating: for example, a sense current of 1 mA through 100 Ω resistor will generate 100 μW of heat. If the sensor element is unable to dissipate this heat, it will report an artificially high temperature. This effect can be reduced by either using a large sensor element, or by making sure that it is in good thermal contact with its environment. The temperature influences on diode characteristics [9] is not actually analyzed here, but the maximal changes are below 1%. The diode

voltage variation is about 2mV/°C and comparing to 600 mV of diodes voltage drop, it is 0.3% generating the total temperature effect in the range of 0.003%/°C.

Table 3

The summary of three linearization solutions.

		Standard linearization		$U_o = \frac{24.601 \cdot 10^{-3} (R_s - 100)}{1 - 0.38071 \cdot 10^{-4} R_s} [V]$		Diode improvement circuit	
T [°C]	R_s [Ω]	U_o [V]	δ_T [%]	U_o [V]	δ_T [%]	U_o [V]	δ_T [%]
-200	18.520	-2.0190	0.95	-2.0187	0.95	-2.0001	0.00
-100	60.256	-1.0009	-0.07	-1.0007	-0.07	-1.0001	0.01
0	100.000	0.0000	0.00	0.0000	0.00	0.0000	0.00
100	138.506	0.9998	-0.02	1.0000	0.00	1.0000	0.00
200	175.856	1.9997	-0.01	2.0000	0.00	2.0000	0.00
300	212.052	2.9983	-0.06	2.9988	-0.04	2.9996	-0.01
400	247.092	3.9938	-0.15	3.9944	-0.14	4.0005	0.01
500	280.978	4.9848	-0.30	4.9855	-0.29	5.0003	0.01
600	313.708	5.9696	-0.51	5.9705	-0.49	5.9992	-0.01
700	345.284	6.9463	-0.77	6.9475	-0.75	7.0002	0.00
800	375.704	7.9132	-1.08	7.9146	-1.06	8.0006	0.01
850	390.481	8.3924	-1.27	8.3939	-1.25	8.4993	-0.01

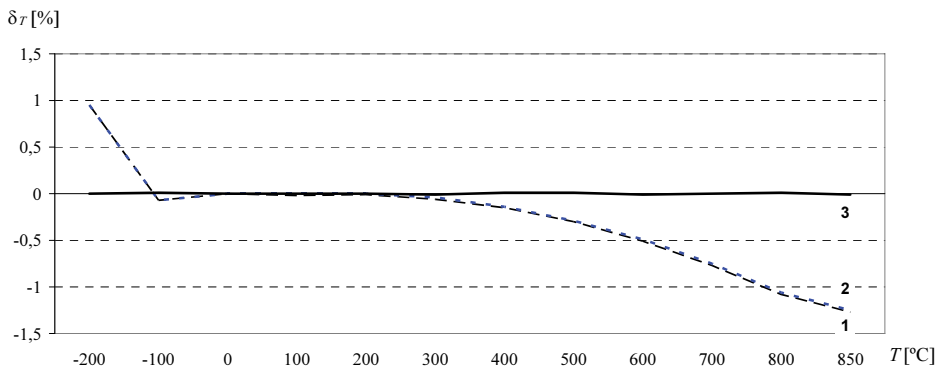

Fig. 9 – *The comparison of relative errors diagram accordingly to Table 3.*

A sample error calculation for a typical RTD measurement circuit (Pt100 RTD, 200 °C measurement span) is provided. Anyway, the error in the whole measuring range should be below 0.1% (see Table 3 and Fig. 9).

6 Conclusion

Like many other sensors, Pt100 has a non-linear transfer function. PRTDs are the most linear class of detectors, but they still exhibit several degrees Celsius of error over the whole measuring range. For some applications, this level of accuracy is unacceptable.

The paper describes the efficient practical solution, for Pt100 sensor linearization in the analog domain using an amplifier with positive feedback. The calibration was performed in four points discussed in Chapter 3, considered as transfer function fragmentation, gives pretty good results (see **Table 1**). The practical transducer realization based on explained principles shows expected results proved in real environment. An experimental model of transducer, which has used described method, was constructed and provided very good performances in Mining and Metallurgy Institute laboratory for thermocouples validation. If the Pt100 working curve linearization achieved on that way is not good enough, it can be improved by using diodes. The simulation method validates excellent results in this case (see **Table 3** and Fig. 9). Also, there is a possibility to make the digital linearization [10]. For instance, it can be implemented with a lookup table or by implementing the generic equation (4). A lookup table located in μ P memory allows conversion (through interpolation) of measured PT100 resistance to corresponding linearized temperature. On the other hand, the previous generic equation offers a possibility of calculating temperature values directly, based on the actual measured RTD resistance [11].

A lookup table necessarily contains a limited number of resistance/temperature values, as dictated by required accuracy and amount of memory available. To calculate a specific temperature, first the two nearest resistance values should be identified (those above and below the measured RTD value), and then interpolate between them.

7 Acknowledgment

This paper is supported by the Grant of the Ministry of Science of Republic of Serbia, as a part of the projects: *Development and application of distributed system for monitoring and control of electrical energy consumption of large consumers – TR33037* and *Development of ecological knowledge-based advanced materials and technologies for multifunctional application – TR 34005* within the framework of Technological development program.

8 References

- [1] D. Stankovic: Physical-Technical Measurements, Naucna knjiga, Belgrade, Serbia, 1987. (In Serbian).
- [2] H.N. Norton: Handbook of Transducers, Prentice Hall, Englewood Cliffs, NJ, USA, 1989.

The Analogue Linearization of Pt100 Working Characteristic

- [3] R. Radetic, D. Milivojevic, D. Brodic, N. Milivojevic: Functional Characteristics of a Resistance Comparator and a Practical Way of their Improvement, *Przeglad Elektrotechniczny (Electrical Review)*, Vol. 89, No. 6, 2013, pp 51 – 55.
- [4] M. Bhuyan: *Intelligent Instrumentation – Principles and Applications*, CRC Press, NY, USA, 2010.
- [5] G.C. Barney: *Intelligent Instrumentation: Microprocessor Applications in Measurement and Control*, Prentice Hall, Englewood Cliffs, NJ, USA, 1988.
- [6] C. Murphy: *Efficient Implementation of Analog Signal Processing Functions in Xilinx All Programmable Devices*, WP442 (v1.0), Xilinx, San Jose, CA, USA, Nov. 2013.
- [7] B. Trump: *Analogue Linearization of Resistance Temperature Detectors*, *Analog Applications Journal*, Vol. 4Q, 2011, pp. 21 – 24.
- [8] Q. Lang, Y. Zhang, W. Xiu: *Dynamic Compensation of Pt100 Temperature Sensor in Petroleum Products Testing based on a Third Order Model*, *International Workshop on Intelligent Systems and Applications*, Wuhan, China, 23-24 May 2009, pp. 1 – 4.
- [9] J. Liu, W.S. Tam, H. Wong, V. Filip: *Temperature-Dependent Light-Emitting Characteristics of InGaN/GaN Diodes*, *Microelectronics Reliability*, Vol. 49, No. 1, Jan. 2009, pp. 38 – 41.
- [10] J.H. Nobbs: *Linearization of the Response from a Platinum Resistance Thermometer*, *Journal of Physics E: Scientific Instruments*, Vol 15, No. 7, July 1982, pp. 716 – 718.
- [11] B. Tawfik: *Temperature Measurement, Lecture Notes*, Cairo University, Cairo, Egypt, 2011.